



Product designation Power contactor
Product type designation BF80

Contact characteristics

Number of poles	Nr.	3
Rated insulation voltage U_i IEC/EN	V	1000
Rated impulse withstand voltage U_{imp}	kV	8
Operational frequency	min	Hz 25
	max	Hz 400
IEC Conventional free air thermal current I_{th}	A	115
Operational current I_e	AC-1 (=40°C)	A 115
	AC-1 (=55°C)	A 95
	AC-1 (=70°C)	A 80
	AC-3 (=440V =55°C)	A 80
	AC-4 (400V)	A 38
Rated operational power AC-3 (T=55°C)	230V	kW 22
	400V	kW 45
	415V	kW 45
	440V	kW 45
	500V	kW 55
	690V	kW 55
	1000V	kW 37
Rated operational power AC-1 (T=40°C)	230V	kW 43
	400V	kW 76
	500V	kW 95
	690V	kW 120
IEC max current I_e in DC1 with L/R = 1ms with 1 poles in series	=24V	A 70
	48V	A 60
	75V	A 60
	110V	A 8
	220V	A –
IEC max current I_e in DC1 with L/R = 1ms with 2 poles in series	=24V	A 100
	48V	A 100
	75V	A 100
	110V	A 80
	220V	A 9
IEC max current I_e in DC1 with L/R = 1ms with 3 poles in series	=24V	A 100
	48V	A 100
	75V	A 100

	110V	A	85
	220V	A	95
<hr/>			
IEC max current I _e in DC1 with L/R = 1ms with 4 poles in series			
	=24V	A	100
	48V	A	100
	75V	A	100
	110V	A	100
	220V	A	115
<hr/>			
IEC max current I _e in DC3-DC5 with L/R = 15ms with 1 poles in series			
	=24V	A	40
	48V	A	30
	75V	A	30
	110V	A	3
	220V	A	–
<hr/>			
IEC max current I _e in DC3-DC5 with L/R = 15ms with 2 poles in series			
	=24V	A	60
	48V	A	50
	75V	A	50
	110V	A	40
	220V	A	5
<hr/>			
IEC max current I _e in DC3-DC5 with L/R = 15ms with 3 poles in series			
	=24V	A	80
	48V	A	70
	75V	A	70
	110V	A	60
	220V	A	64
<hr/>			
IEC max current I _e in DC3-DC5 with L/R = 15ms with 4 poles in series			
	=24V	A	90
	48V	A	90
	75V	A	90
	110V	A	75
	220V	A	80
<hr/>			
Short-time allowable current for 10s (IEC/EN60947-1)		A	640
<hr/>			
Protection fuse			
	gG (IEC)	A	125
	aM (IEC)	A	80
<hr/>			
Making capacity (RMS value)		A	800
<hr/>			
Breaking capacity at voltage			
	440V	A	640
	500V	A	625
	690V	A	456
<hr/>			
Resistance per pole (average value)		m?	0.6
<hr/>			
Power dissipation per pole (average value)			
	I _{th}	W	7.9
	AC3	W	3.8
<hr/>			
Tightening torque for terminals			
	min	Nm	4
	max	Nm	5
	min	I _{bin}	2.95
	max	I _{bin}	3.69
<hr/>			
Tightening torque for coil terminal			
	min	Nm	0.8
	max	Nm	1

		min	I _{bin}	0.8
		max	I _{bin}	0.74
Max number of wires simultaneously connectable			Nr.	2
Conductor section	AWG/Kcmil			
		max		2
Flexible w/o lug conductor section		min	mm ²	1.5
		max	mm ²	35
Flexible c/w lug conductor section		min	mm ²	1.5
		max	mm ²	35
Power terminal protection according to IEC/EN 60529				IP20 front
Mechanical features				
Operating position		normal allowable		Vertical plan ±30°
Fixing				Screw / DIN rail 35mm
Weight			g	1060
Conductor section	AWG/kcmil conductor section			
		max		2
Operations				
Mechanical life			cycles	15000000
Electrical life			cycles	1300000
Safety related data				
Performance level B10d according to EN/ISO 13489-1		rated load	cycles	1300000
		mechanical load	cycles	15000000
Mirror contacts according to IEC/EN 60947-4-1				yes
EMC compatibility				yes
AC coil operating				
Rated AC voltage at 50/60Hz, 60Hz		min	V	20
		max	V	48
Rated AC voltage at 50/60Hz			V	24
AC operating voltage	of 50/60Hz coil powered at 50Hz			
	pick-up	min	%Us	80 Us min
		max	%Us	110 Us max
	drop-out	max	%Us	=70 Us min
	of 50/60Hz coil powered at 60Hz			
	pick-up	min	%Us	80 Us min
		max	%Us	110 Us max
	drop-out	max	%Us	=70 Us min
AC average coil consumption at 20°C	of 50/60Hz coil powered at 50Hz			
		in-rush	VA	35...120

	holding	VA	1.5...3.7
of 50/60Hz coil powered at 60Hz			
	in-rush	VA	35...120
	holding	VA	1.5...3.7
Dissipation at holding =20°C 50Hz		W	1...2.5
DC coil operating			
DC rated control voltage			
	min	V	20
	max	V	48
DC rated control voltage		V	24
DC operating voltage			
pick-up		min	%Us 85 Us min
		max	%Us 110 Us max
drop-out		max	%Us =70 Us min
Average coil consumption =20°C			
	in-rush	W	23...68
	holding	W	1.2...1,9
Max cycles frequency			
Mechanical operation		cycles/h	1500
Operating times			
Average time for Us control			
in AC			
Closing NO		min	ms 12
		max	ms 28
Opening NO		min	ms 8
		max	ms 22
in DC			
Closing NO		min	ms 40
		max	ms 85
Opening NO		min	ms 20
		max	ms 55
UL technical data			
Full-load current (FLA) for three-phase AC motor			
	at 480V	A	77
	at 600V	A	77
Yielded mechanical performance			
for three-phase AC motor			
	200/208V	HP	25
	220/230V	HP	30
	460/480V	HP	60
	575/600V	HP	75
General USE			
Contactor			
	AC current	A	115
Short-circuit protection fuse, 600V			
High fault			
	Short circuit current	kA	100
	Fuse rating	A	200

	Fuse class	J
Standard fault		
	Short circuit current	kA 10
	Fuse rating	A 200
	Fuse class	RK5

Ambient conditions

Temperature

Operating temperature

min	°C	-40
max	°C	70

Storage temperature

min	°C	-50
max	°C	80

Max altitude

m 3000

Resistance & Protection

Pollution degree

3

Dimensions

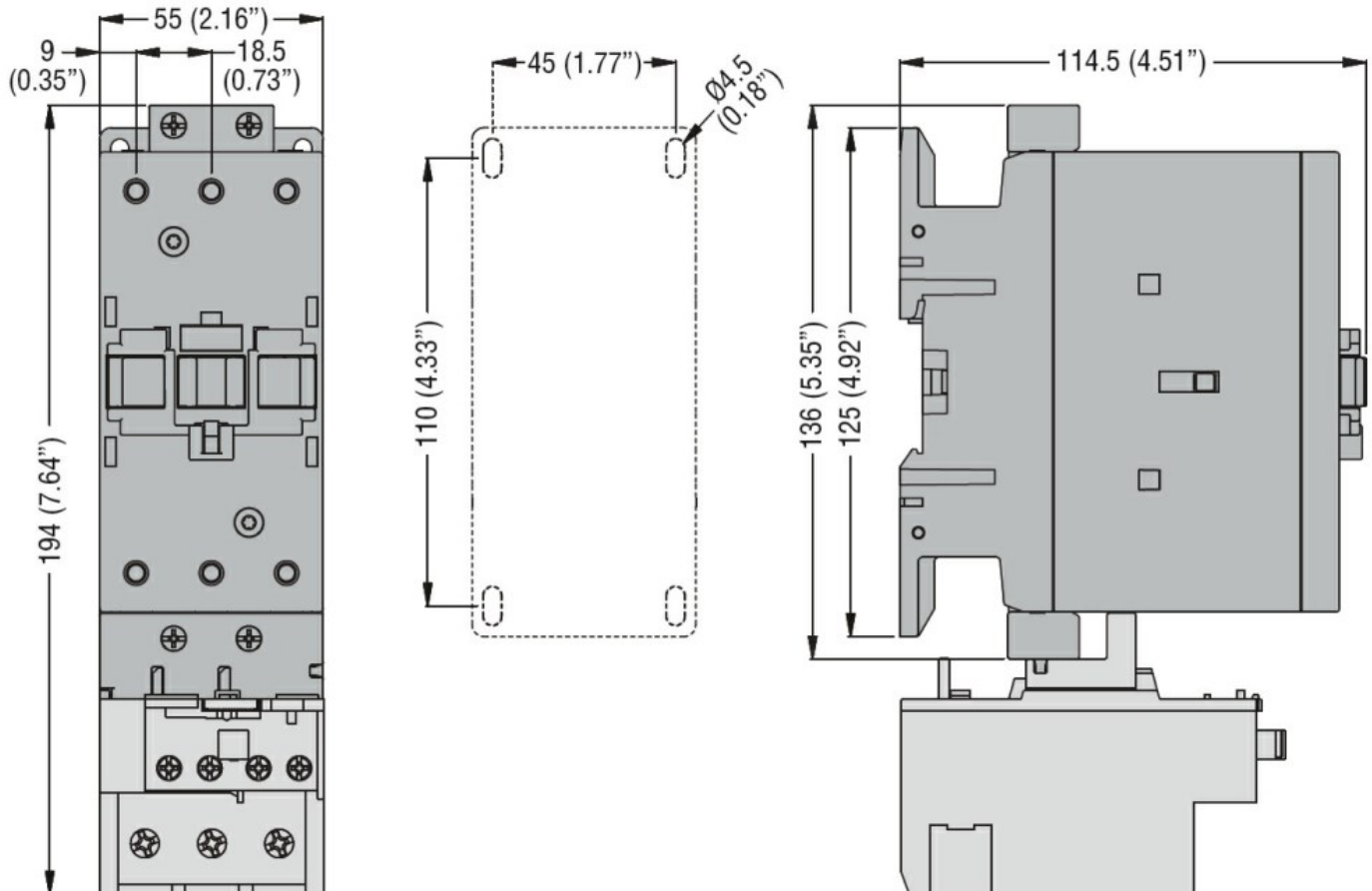

Wiring diagrams

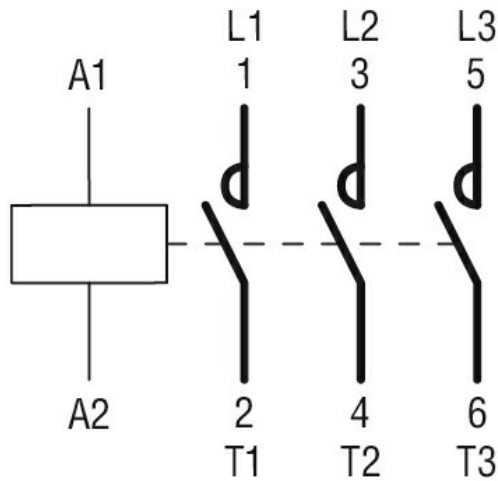

Certifications and compliance

Compliance

CSA C22.2 n° 60947-1

CSA C22.2 n° 60947-4-1

IEC/EN/BS 60947-1

IEC/EN/BS 60947-4-1

UL 60947-1

UL 60947-4-1

Certificates

CCC

cULus

ETIM classification

ETIM 8.0

EC000066 -
 Power contactor,
 AC switching